

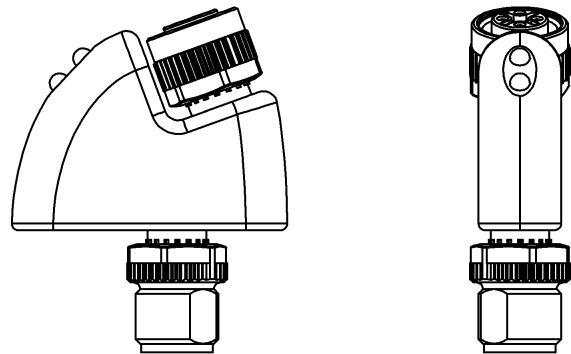



FNI IOL-712-000-K023  
FNI IOL-714-000-K023  
User's Guide



## Content

<b>1</b>	<b>Notes</b>	<b>2</b>
1.1.	Structure of the guide	2
1.2.	Typographical conventions	2
	Enumerations	2
	Actions	2
	Syntax	2
	Cross references	2
1.3.	Symbols	2
1.4.	Abbreviations	2
1.5.	Deviating views	2
<b>2</b>	<b>Safety</b>	<b>3</b>
2.1.	Intended use	3
2.2.	Installation and startup	3
2.3.	General safety notes	3
2.4.	Resistance to aggressive substances	3
	Hazardous voltage	3
<b>3</b>	<b>Getting started</b>	<b>4</b>
3.1.	Connection overview	4
3.2.	Mechanical connection	4
3.3.	Electrical connection	4
3.4.	IO-Link interface	4
	Connecting the module	4
	Module versions	5
3.5.	Sensor interface	5
<b>4</b>	<b>IO-Link interface</b>	<b>6</b>
4.1.	IO-Link data	6
4.2.	Process data / input data	6
	FNI IOL-712-000-K023	6
	FNI IOL-714-000-K023	6
4.3.	Parameter data/ Request data	7
4.4.	Errors	7
4.5.	Events	7
<b>5</b>	<b>Technical data</b>	<b>8</b>
5.1.	Dimensions	8
5.2.	Mechanical data	8
5.3.	Electrical data	8
5.4.	Operating conditions	8
5.5.	LED indicators	9
	Status LED	9
<b>6</b>	<b>Appendix</b>	<b>10</b>
6.1.	Product ordering code	10
6.2.	Order information	10
6.3.	Scope of delivery	10

## 1 Notes

- 1.1. Structure of the guide** The guide is organized so that the sections build on one another.  
Section 2: Basic safety information.  
.....
- 1.2. Typographical conventions** The following typographical conventions are used in this guide.
- Enumerations** Enumerations are shown in list form with bullet points:
- Entry 1
  - Entry 2
- Actions** Action instructions are indicated by a preceding triangle. The result of an action is indicated by an arrow.
- Action instruction 1
  - ↪ Action result
  - Action instruction 2
- Syntax** Numbers:  
Decimal numbers are shown without additional indicators (e.g. 123),  
Hexadecimal numbers are shown with the additional indicator hex (e.g. 00hex).
- Cross references** Cross references indicate where additional information on the topic can be found.
- 
- 1.3. Symbols**
-  **Note**  
This symbol indicates general notes.
- 
-  **Attention!**  
This symbol indicates a security notice which must be observed.
- 
- 1.4. Abbreviations**
- |        |                               |
|--------|-------------------------------|
| FNI    | FAS Network Interface         |
| I-Port | Standard input port           |
| DPP    | Direct parameter page         |
| IOL    | IO-Link                       |
| EMC    | Electromagnetic compatibility |
| FE     | Function ground               |
| SPDU   | Service Protocol Data Unit    |
- 1.5. Deviating views** Product views and illustrations in this user's guide may differ from the actual product. They are intended only as illustrative material.

**2.1. Intended use** This guide describes the FAS Network Interface FNI IOL-712/714-000-K023 for the application as peripheral output module to connect analogue sensors. Hereby it is about an IO-Link device which communicates by means of IO-Link protocol with the superordinate IO-Link master assembly.

**2.2. Installation and startup**



**Attention!**

Installation and startup are to be performed only by trained specialists. Qualified personnel are persons who are familiar with the installation and operation of the product, and who fulfill the qualifications required for this activity. Any damage resulting from unauthorized manipulation or improper use voids the manufacturer's guarantee and warranty. The Operator is responsible for ensuring that applicable safety and accident prevention regulations are complied with.

**2.3. General safety notes**

**Commissioning and inspection**

Before commissioning, carefully read the operating manual.

The system must not be used in applications in which the safety of persons is dependent on the function of the device.

**Authorized Personnel**

Installation and commissioning may only be performed by trained specialist personnel.

**Intended use**

Warranty and liability claims against the manufacturer are rendered void by:

- Unauthorized tampering
- Improper use
- Use, installation or handling contrary to the instructions provided in this operating manual

**Obligations of the Operating Company**

The device is a piece of equipment from EMC Class A. Such equipment may generate RF noise. The operator must take appropriate precautionary measures. The device may only be used with an approved power supply. Only approved cables may be used.

**Malfunctions**

In the event of defects and device malfunctions that cannot be rectified, the device must be taken out of operation and protected against unauthorized use.

Intended use is ensured only when the housing is fully installed.

**2.4. Resistance to aggressive substances**



**Attention!**

The FNI modules generally have a good chemical and oil resistance. When used in aggressive media (eg chemicals, oils, lubricants and coolants each in high concentration (ie, low water content)) must be checked prior application-related material compatibility. In the event of failure or damage to the FNI modules due to such aggressive media are no claims for defects.

**Hazardous voltage**



**Attention!**

Disconnect all power before servicing equipment.



**Note**

In the interest of product improvement, the FAS reserves the right to change the specifications of the product and the contents of this manual at any time without notice.

3 Getting started

3.1. Connection overview

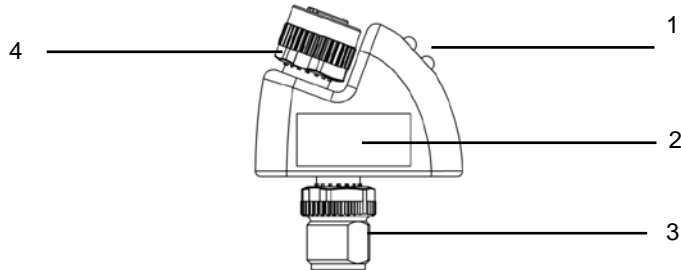

Figure 3-1: FNI IOL-...-K023

- 1 Status LED: Supply, Communication
- 2 Label
- 3 IO-Link interface
- 4 Analogue input port

3.2. Mechanical connection

To avoid long, shielded analogue cables, the FNI IOL-712/714-000-K023 modules should be attached to the analogue unit which has to be connected. No further mechanical attachment is required.

3.3. Electrical connection

The FNI IOL-712/714-000-K023 modules require no separate supply voltage connection. Power is provided through the IO-Link interface by the superordinate IO-Link Master Assembly.

3.4. IO-Link interface

IO-Link (M12, A-coded, male)

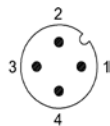

Pin	Signal
1	Supply voltage, +24V
2	-
3	GND, reference potential
4	C/Q, IO-Link Data transmission channel

Connecting the module

- Connect the FNI IOL-...-K023 either to an IO-Link Master directly or to an analogue sensor.
- Connect the male plugs unconnected by using cables.



**Note**

A standard 3 wire sensor cable is used for connection to the host IO-Link master.



**Note**

A shielded 4 wire sensor cable is used for connection to the analog actuator.

### 3 Getting started

#### Module versions

Module versions	Analogue port
FNI IOL-712-000-K023	Current input(4-20mA)
FNI IOL-714-000-K023	Voltage input (0-10V)

#### 3.5. Sensor interface

Analogue input port (M12, A-coded, female)

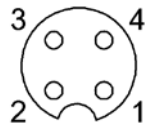

Pin	Signal
1	+24V, mA*
2	Voltage input 0-10V <sup>2)</sup>
3	GND
4	Current input 0-20mA <sup>1)</sup>

1) Only in case of FNI IOL-712-000-K023

2) Only in case of FNI IOL-714-000-K023

\* Depending on the IO-Link master, but max. 2A.

4 IO-Link interface

4.1. IO-Link data

FNI IOL-712-000-K023

Data transmission rate	COM2 (38,4 kBaud)
Frame type	2.2
Minimal cycle time	3 ms
Process data cycles	3 ms, at minimal cycle time
Prozess data length	2 byte input

FNI IOL-714-000-K023

Data transmission rate	COM2 (38,4 kBaud)
Frame type	2.2
Minimal cycle time	3 ms
Process data cycles	3 ms, at minimal cycle time
Prozess data length	2 byte input

4.2. Process data / input data

FNI IOL-712-000-K023

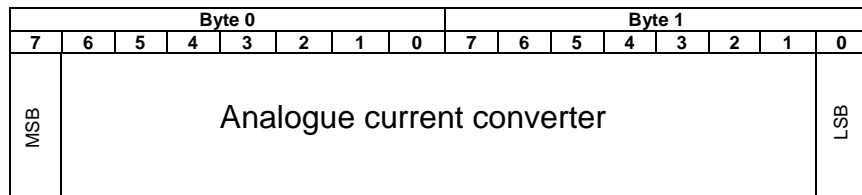

FNI IOL-714-000-K023

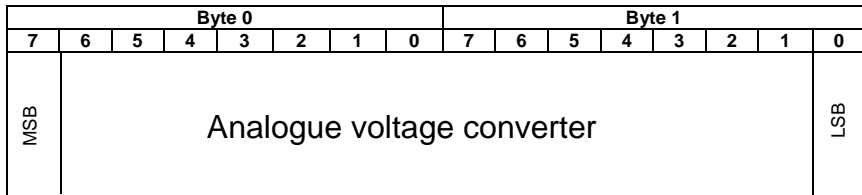

---

**i Note**  
The measuring range from 0 – 21.15 mA (for FNI IOL-712-000-K023) will be shown in 16384 steps.

---

**i Note**  
The measuring range from 0 - 10 Volt (for FNI IOL-714-000-K023) will be shown in 16384 steps.

---

4.3. Parameter data/  
Request data

	DPP	SPDU		Object name	Length	Range	Default value
	Index	Index	Sub-Index				
Identification Data	0x07			Vendor ID	2 Byte	read only	0x0454
	0x08						
	0x09			Device ID	3 Byte		0x099BE2 0x099BE1
	0x0A						
	0x0B						
		0x10	0	Vendor name	18 Byte		FAS(Fujian)Co.,LTD
		0x11	0	Vendor text	16 Byte		www.fas-elec.com
		0x12	0	Product name	19 Byte		FNI IOL-712-000-K023 FNI IOL-714-000-K023
		0x13	0	Product ID	7 Byte		0AC021 0AC001
		0x14	0	Product text	18 Byte		IO-Link 1AI 0...20mA IO-Link 1AI 0...10V
	0x16	0	Hardware Revision	1 Byte	1.0		
	0x17	0	Firmware Revision	23 Byte	1.0		
Parameter Data		-					

4.4. Errors

Error Code	Additional Code
Device application error 0x80	Index not available 0x11
Device application error 0x80	Subindex not available 0x12
Device application error 0x80	Value out of range 0x30

4.5. Events

Class / Qualifier			Code ( high + low)			
Mode	Type	Instance				
Appears	Error	AL	Device Hardware	Supply	Supply low voltage	U2 = Supply + 24V
			0x5000	0x0100	0x0010	0x0002
0xF3			0x5112			
Disappears	Error	AL	Device Hardware	Supply	Supply low voltage	U2 = Supply + 24V
			0x5000	0x0100	0x0010	0x0002
0xB3			0x5112			



5 Technical data

5.1. Dimensions

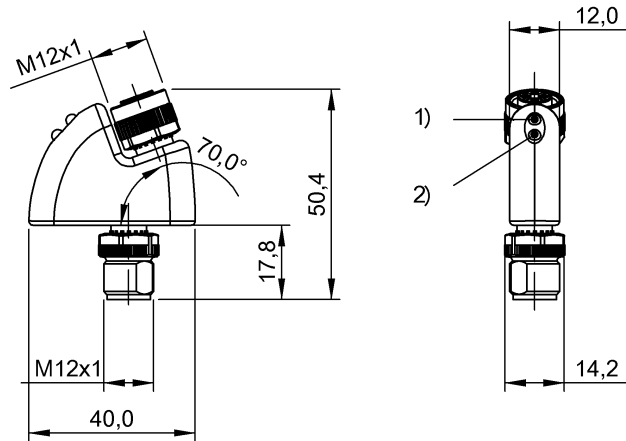

Figure 5-1: Dimensions FNI IOL-...-K023

5.2. Mechanical data

Housing materials	Plastic, Macromelt 6208
IO-Link port	M12, A-coded, male
I-port	M12, A-coded, female
Enclosure rating per IEC 60529	IP 67 (only when plugged in and threaded in)
Dimensions (W x H x D in mm)	40 x 50.4 x 14.2
Weight	ca. 50 g

5.3. Electrical data

Operating voltage	18...30.2 V DC, per EN 61131-2
Ripple	< 1%
Current draw without load	<= 30 mA
Resolution	12bit
Sampling rate	3ms

5.4. Operating conditions

Operating temperature	-5 °C ... 70 °C
Storage temperature	-25 C ... 70 °C

5.5. LED indicators

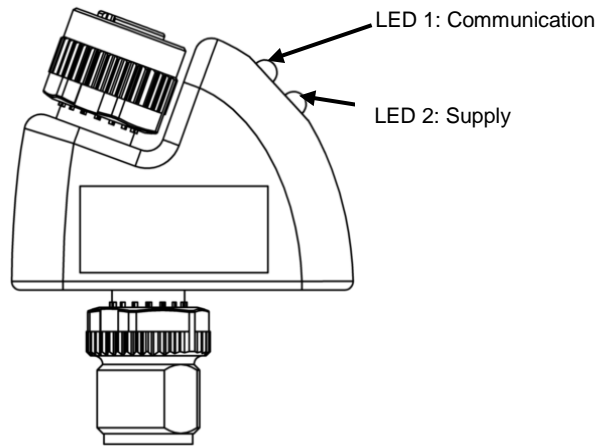

Figure 5-2: LED indicators

Status LED

FNI IOL-71x-000-K023

LED	Indicator	Function
LED 1	Green / Green flashing	Communication error / Communication ok
LED 2	Green / Green flashing	Supply sensor & module ok / Undervoltage

## 6 Appendix

### 6.1. Product ordering code

FNI IOL-71x-000-K023

FAS Network Interface

IO-Link interface

Functions

712 = Current input 4-20mA

714 = Voltage input 0-10V

Versions

000 = Standard design

Mechanical design

K023 = Plastic housing, Hotmelt

Bus connection and voltage supply 1xM12 male, 4-poles, external thread

Analogue port: 1xM12, female, 4-poles, internal thread

### 6.2. Order information

Order code	Material number	Product ordering code	Label color	Printing IN or OUT
0AC021	213978	FNI IOL-712-000-K023	Red (RAL5015)	I
0AC001	213979	FNI IOL-714-000-K023	Blue (RAL3020)	I

### 6.3. Scope of delivery

FNI IOL-...-K023 consists of the following components:

- IO-Link module
- User's guide

**www.fas-elec.com**

FAS Electronics  
Room 05, Floor 18,  
Wangneng Building, Keji East  
Road, Shangjie Town, Fuzhou  
Tel. +86 591 2278 1506  
Fax +86 591 2278 1506  
sales@fas-elec.com  
www.fas-elec.com